



HAYTER

MAKERS OF THE FINEST MOWERS

Parts Catalogue

R53S Recycling Mower

Code 448F

Serial No.312000001

Manual Part No. 3373-359 Rev A

Ordering Replacement Parts

To order replacement parts, please supply the part number, the quantity, and the description of each part desired.

Understanding Reference Numbers

Each identified part in an illustration has a reference number. The reference number for a part also appears in the parts list, along with other information about the part.

This catalog uses two special reference number formats, one to indicate parts in a service assembly and another to indicate the quantity of a given part in an illustration.

Service Assembly Reference Numbers

Parts in service assemblies have reference numbers in the form a:b. The a represents the reference number of the entire service assembly and the b represents a sequential number unique to each part within the service assembly.

For example, a wheel assembly might be identified by reference number 6, the tire by 6:1, the valve by 6:2, and the wheel by 6:3. When you order the assembly identified by reference number 6, you receive all parts identified by reference numbers 6:1, 6:2, and 6:3. However, you may also order any part individually. Reference numbers of this type appear in illustration and in parts lists.

Reference Numbers Indicating Quantity

In an illustration, if a reference number indicates more than one part, the reference number has the form nX y. The n represents the quantity of the part, the X is the multiplication symbol, and the y represents the reference number.

For example, in an illustration, the reference number 2X 37 means that two of the parts identified by reference number 37 are indicated.

List of Abbreviations

AR: as required

ASM: assembly

BBC: blade brake control

BHTF: button head thread forming

CARR: carriage

CCW: counter clockwise

CW: clockwise

DEG: degrees

DPA: Dual Point Adjustment

ECM: electronic control module

EXT: external

FH: flat head

GA: gauge

HD: heavy-duty

HF: hex flange

HH: hex head

HHF: hex head flange

HHFTF: hex head flange thread forming

HJ: hex jam

HLH: hex lag head

HOC: height-of-cut

HSBH: hex socket button head

HSFH: hex socket flat head

HSH: hex socket head

HWH: hex washer head

HWHTF: hex washer head thread forming

HYD: hydraulic

LH: left hand

LPG: Liquid Propane Gas

NI: nylon insert

NPTF: national pipe thread fine

PFH: phillips flat head

PPH: phillips pan head

PPHTF: phillips pan head thread forming

PRH: phillips round head

PTH: phillips truss head

PTO: power-take-off

RH: right hand

ROPS: roll-over protection system

RRB: rear roller brush

SFH: slotted fillister head

SHH: slotted hex head

SHWH: slotted hex washer head

SPH: slotted pan head

SQH: square head

SRH: slotted round head

STD: standard

TAP: self tapping

TTH: torx truss head

Contents

Housing, Rear Cover and Front Axle Assembly	4
Deck Baffle Assembly No. 117-4113	5
Rear Wheel, Transmission and Side Discharge Chute Assembly	6
Upper Handle Assembly	7
Lower Handle Assembly	8
Engine and Blade Assembly	9
Electrical Assembly	10
Bag Assembly	11

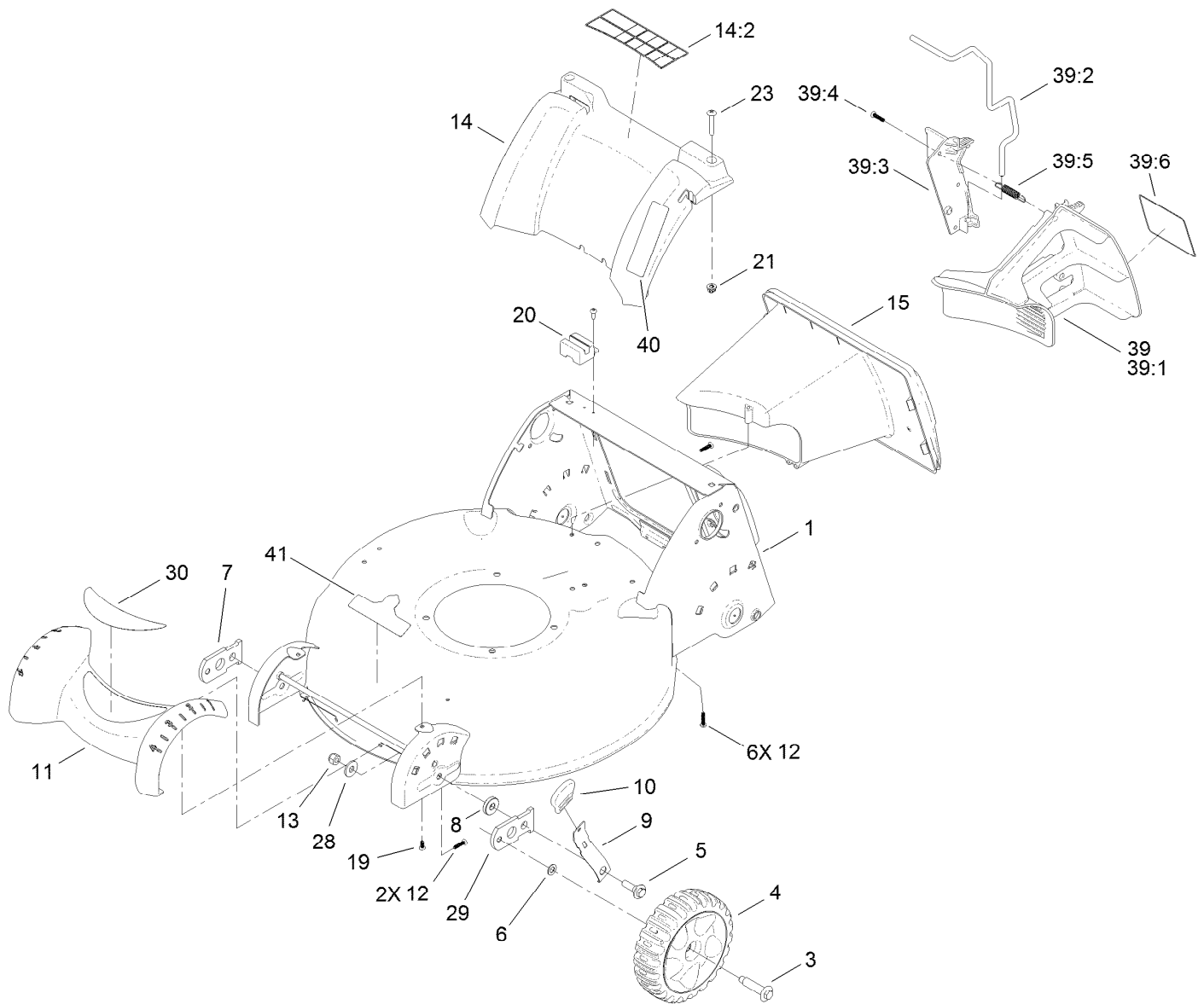

Housing, Rear Cover and Front Axle Assembly

Ref.	Part Number	Qty.	Description	Ref.	Part Number	Qty.	Description
1	117-4113	1	Deck Baffle ASM	20	110-1787	1	Module-Switch
3	614650	2	Bolt-Shoulder	21	94-1610	2	Nut-Clip
4	117-5964	2	7 Inch Wheel And Tire ASM	23	108-0965	2	Screw-PTH
5	614672	2	Bolt-Shoulder	28	80-6990	2	Washer-Hardened
6	40-1940	2	Washer	29	108-1044	1	Arm-Pivot, LH
7	107-3877	1	Arm-Pivot, RH	30	111-2211	1	Decal-Front
8	92-4890	2	Washer	39	110-9468	1	Mulch Plug ASM
9	107-3878	2	Arm-Spring	39:1	110-9446	1	Plug-Mulch, LH
10	110-7125	2	Knob-HOC	39:2	110-9448	1	Latch-Plug, Mulch
11	107-3926	1	Cover-Front	39:3	110-9447	1	Plug-Mulch, RH
12	108-7476	8	Screw-Plastite	39:4	108-7476	3	Screw-Plastite
13	3296-39	2	Nut-Lock, NI	39:5	110-9458	1	Spring-Extension
14	115-3177	1	Cover-Rear	39:6	110-9457	1	Decal-Plug, Mulch
14:2	114-2820	1	Decal-Warning	40	111-2210	1	Decal-Handle Adjust
15	110-9456	1	Tunnel	41	410087	1	Decal
19	108-7475	2	Screw-Plastite				

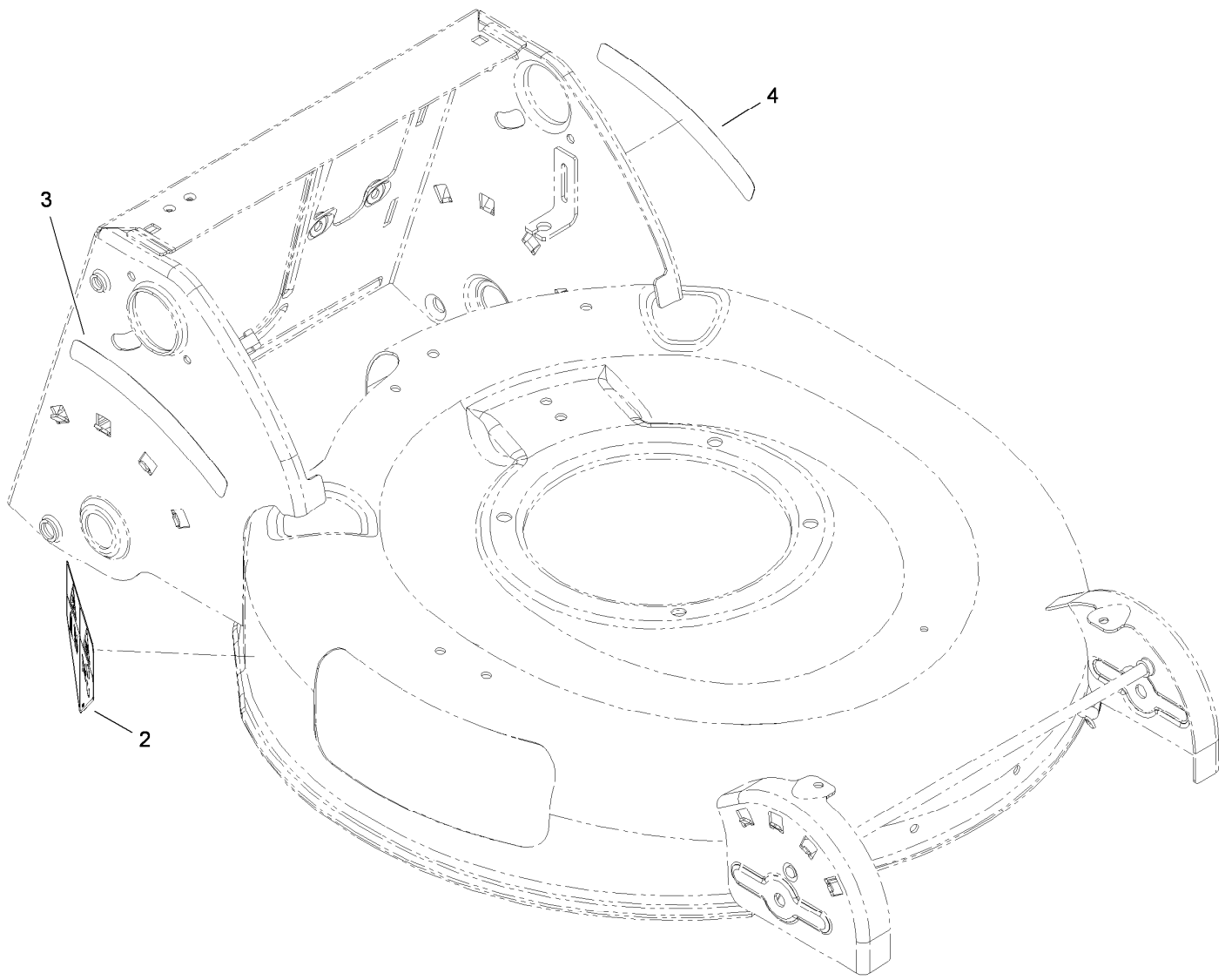

Deck Baffle Assembly No. 117-4113

<i>Ref.</i>	<i>Part Number</i>	<i>Qty.</i>	<i>Description</i>
2	112-8760	1	Decal-Danger
3	108-7450	1	Decal-HOC, RH
4	108-7451	1	Decal-HOC, LH

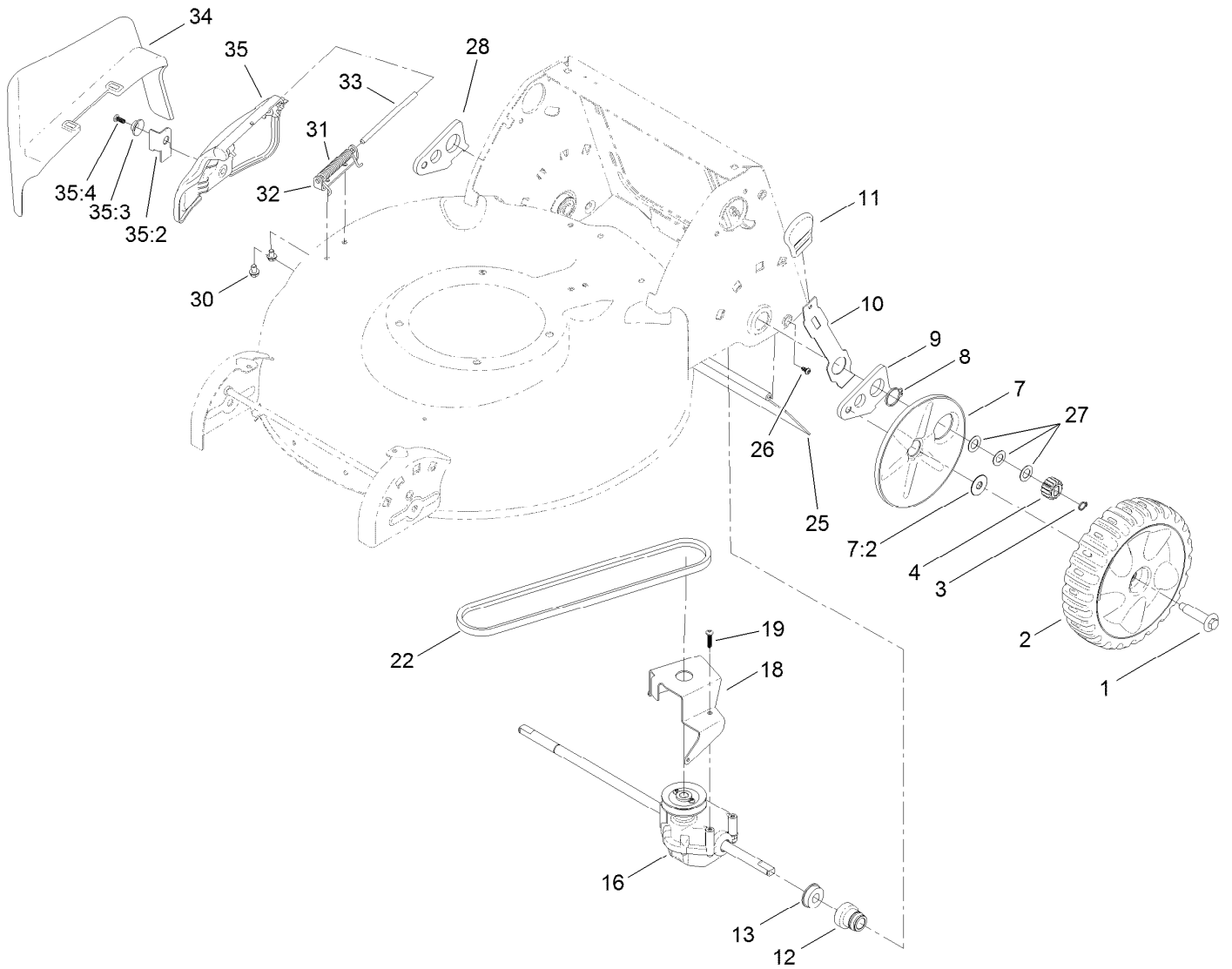

Rear Wheel, Transmission and Side Discharge Chute Assembly

<i>Ref.</i>	<i>Part Number</i>	<i>Qty.</i>	<i>Description</i>	<i>Ref.</i>	<i>Part Number</i>	<i>Qty.</i>	<i>Description</i>
1	614650	2	Bolt-Shoulder	19	108-7476	3	Screw-Plastite
2	119-7074	2	8 Inch Wheel And Gear ASM	22	110-9429	1	V-Belt
3	32151-61	2	Ring-Retaining	25	120-7010	1	Shield-Trailing
4	110-9417	2	Gear-Pinion, 15T	26	117-1092	2	Screw-PTH
7	117-4197	2	Wheel Cover ASM	27	36-4780	3	Washer-Plain
7:2	614426	1	Washer-Stepped	28	108-9343	1	Arm-Rear Pivot, RH
8	32151-36	2	Ring-Retaining	30	99-8445	2	Screw-HWH, Taptite
9	108-9344	1	Arm-Rear Pivot, LH	31	99-5293	1	Spring-Torsion
10	110-9445	2	Arm-Spring, Rear	32	112-6416	1	Bracket-Cover
11	110-7125	2	Knob-HOC	33	99-5291	1	Rod-Cover
12	104-8698	2	Retainer-Bearing, HOC	34	105-3028	1	Chute-Discharge, Side
13	104-8699	2	Bearing-Ball	35	106-8376	1	Discharge Door ASM
16	110-9414	1	Transmission ASM	35:2	107-0795	1	Latch-Door
18	114-7977-03	1	Bracket-Transmission	35:3	107-7456	1	Cap-Door
				35:4	107-7461	1	Screw-Plastite

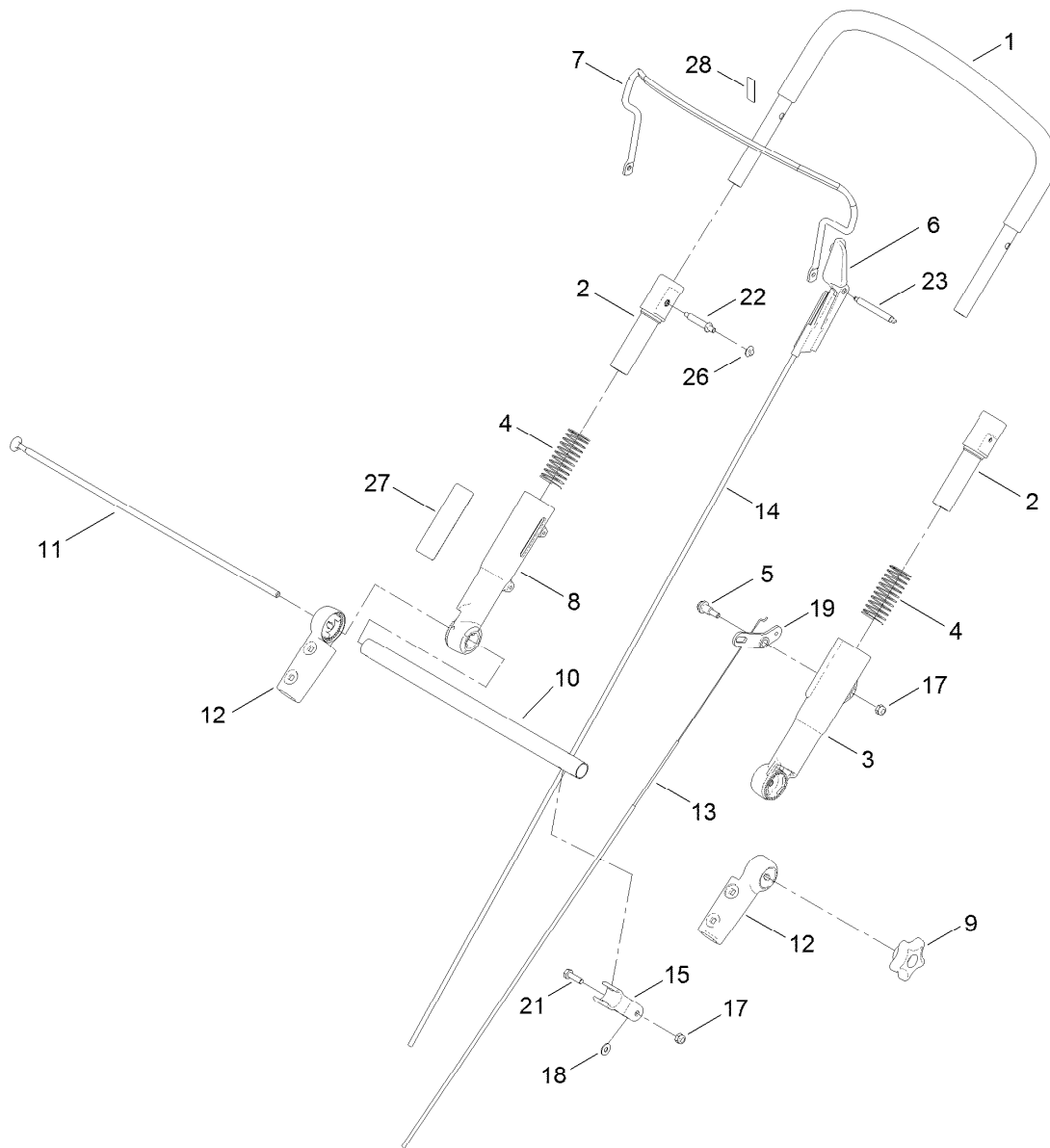

Upper Handle Assembly

<i>Ref.</i>	<i>Part Number</i>	<i>Qty.</i>	<i>Description</i>	<i>Ref.</i>	<i>Part Number</i>	<i>Qty.</i>	<i>Description</i>
1	108-0974	1	Upper Handle ASM	13	107-3902	1	Cable-Traction
2	112-8754	2	Sleeve-Inner	14	107-3903	1	Cable-Brake
3	112-1544	1	Sleeve-Outer, LH	15	112-8801	1	Clamp-Cable
4	107-3869	2	Spring-Compression	17	3296-73	2	Nut-Lock, NI
5	104-0858	1	Bolt-Shoulder	18	3256-1	1	Washer-Flat
6	112-8764	1	Stop-Pivot	19	107-3893	1	Lever-Traction
7	110-1819-03	1	Bail-Brake	21	321-5	1	Screw-HH
8	112-1545	1	Sleeve-Outer, RH	22	108-0959	1	Pin-Handle
9	117-5976	1	Knob-Handle, Locking	23	108-1008	1	Pin-Bail, LH
10	107-3867-03	1	Tube-Cross	26	108-9378	1	Retainer-Push On
11	107-3871	1	Rod-Threaded	27	111-2209	1	Decal-Sens A Speed
12	107-3865	2	Mount-Handle, Lower	28	117-4157	1	Decal-Engine Stop

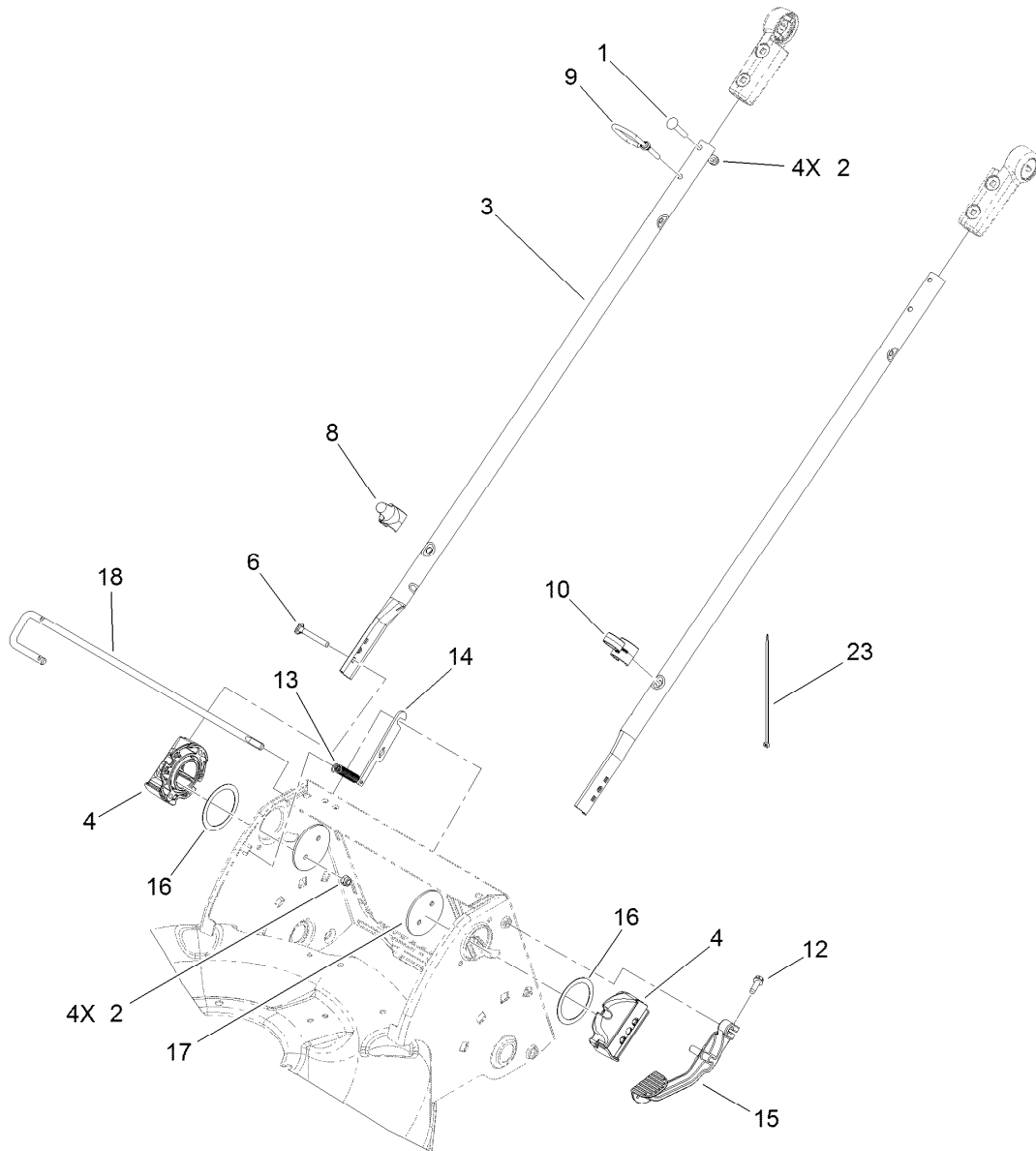

Lower Handle Assembly

<i>Ref.</i>	<i>Part Number</i>	<i>Qty.</i>	<i>Description</i>	<i>Ref.</i>	<i>Part Number</i>	<i>Qty.</i>	<i>Description</i>
1	108-0988	3	Screw-CARR	12	49-2040	1	Screw-HWHTF
2	3296-73	8	Nut-Lock, NI	13	112-1542	1	Spring-Extension
3	107-3887-03	2	Tube-Lower	14	112-1539	1	Plate-Rod, Release
4	119-3847-03	2	Mount-Handle	15	110-1823-03	1	Lever-Release
6	95-4453	4	Screw	16	107-3947	2	Washer-Nylon
8	117-4141	1	Guide-Rope, Lower	17	107-3944-03	2	Plate
9	107-3908	1	Guide-Rope, Upper	18	112-8755	1	Rod-Release, Handle
10	114-7988	1	Guide-Cable	23	614249	1	Tie-Cable

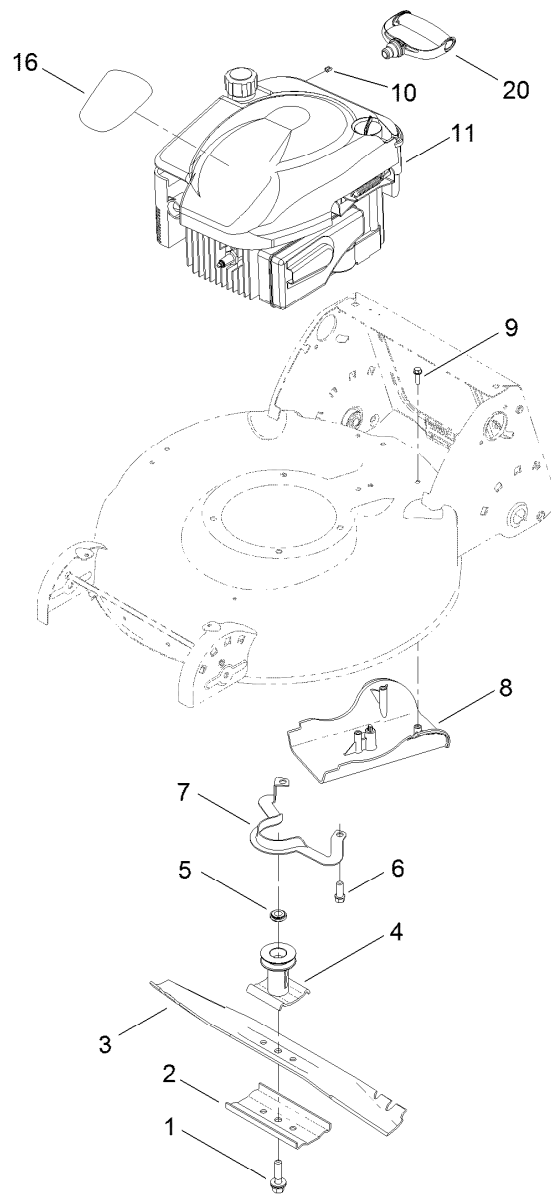

Engine and Blade Assembly

Ref.	Part Number	Qty.	Description
1	105-8579	1	Bolt-Blade
2	108-3766-03	1	Support-Blade
3	108-0954-03	1	Blade-21 Inch
4	106-3987	1	Blade Driver ASM
5	106-3999	1	Spacer-Driver
6	95-1726	3	Screw-Taptite
7	105-3030-03	1	Guide-Belt
8	110-1832	1	Cover-Belt
9	46-8091	3	Screw-HWH
10	2210-316	1	Stop-Rope
11		1	Engine-Briggs, 126M070127F1 ●■
16	111-3208	1	Decal-Shroud
20	117-4142	1	Handle-Recoil

● Not serviced separately

■ Obtain parts from www.briggsandstratton.com

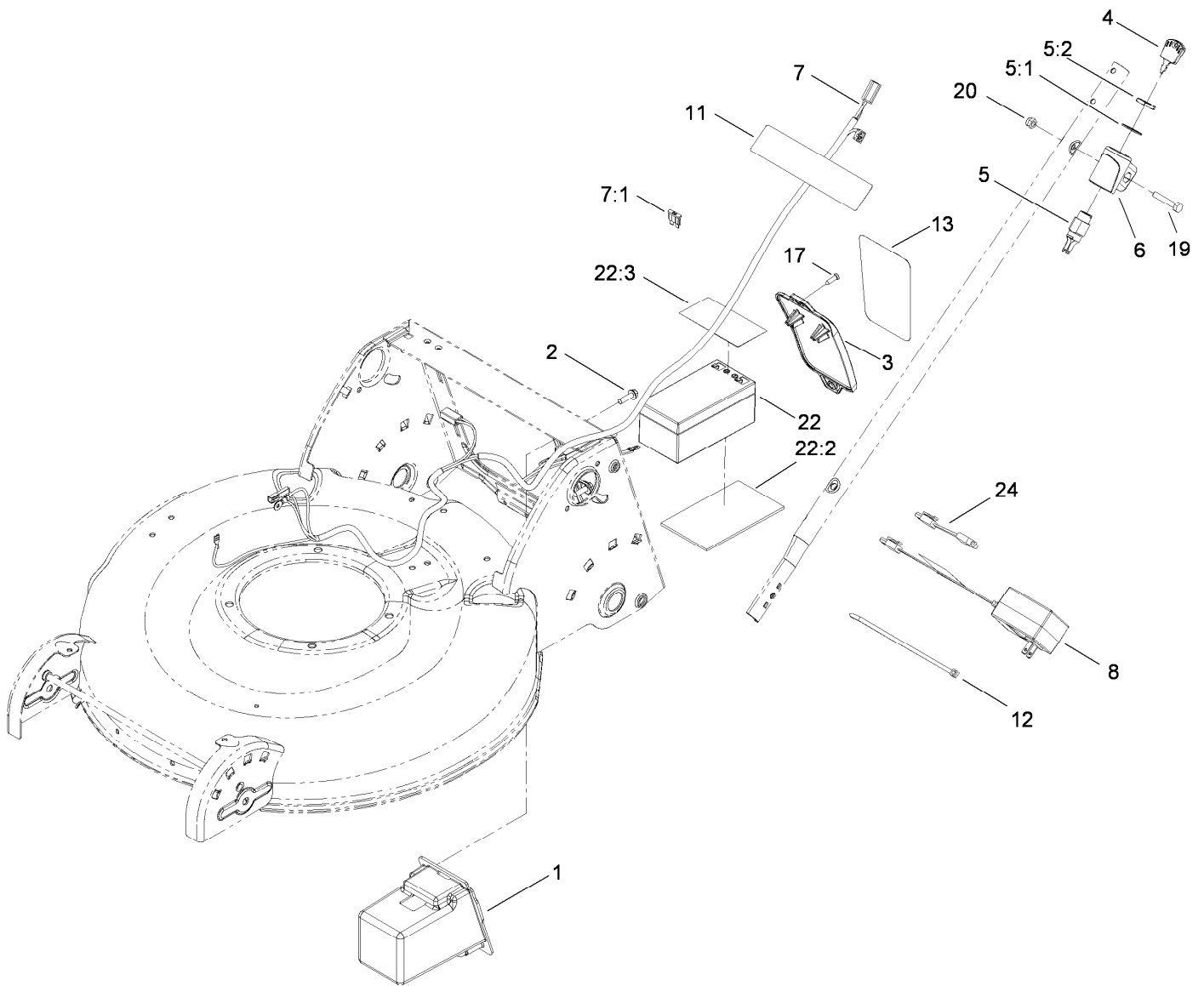

Electrical Assembly

<i>Ref.</i>	<i>Part Number</i>	<i>Qty.</i>	<i>Description</i>	<i>Ref.</i>	<i>Part Number</i>	<i>Qty.</i>	<i>Description</i>
1	107-3932	1	Box-Battery	11	104-7953	1	Decal
2	46-8091	4	Screw-HWH	12	614249	2	Tie-Cable
3	108-0981	1	Cover-Battery	13	108-0992	1	Decal-Instruction, Battery
4	700918	1	Key	17	32144-111	2	Screw-PPH
5	46-5780	1	Starter Switch ASM	19	321-51	1	Screw-HH
5:1	3254-5	1	Washer-Tooth, Internal	20	3296-73	1	Nut-Lock, NI
5:2	218-461	1	Nut-HH	22	108-9358	1	Battery
6	108-9760	1	Mount-Switch	22:2	108-0987	1	Foam-Battery
7	119-2251	1	Harness-Wire	22:3	112-8763	1	Decal-Terminal, Battery
7:1	99-6124	1	Fuse-Blade, 40 Amp	24	107-3749	1	Adapter-Charger
8	117-4108	1	Charger				

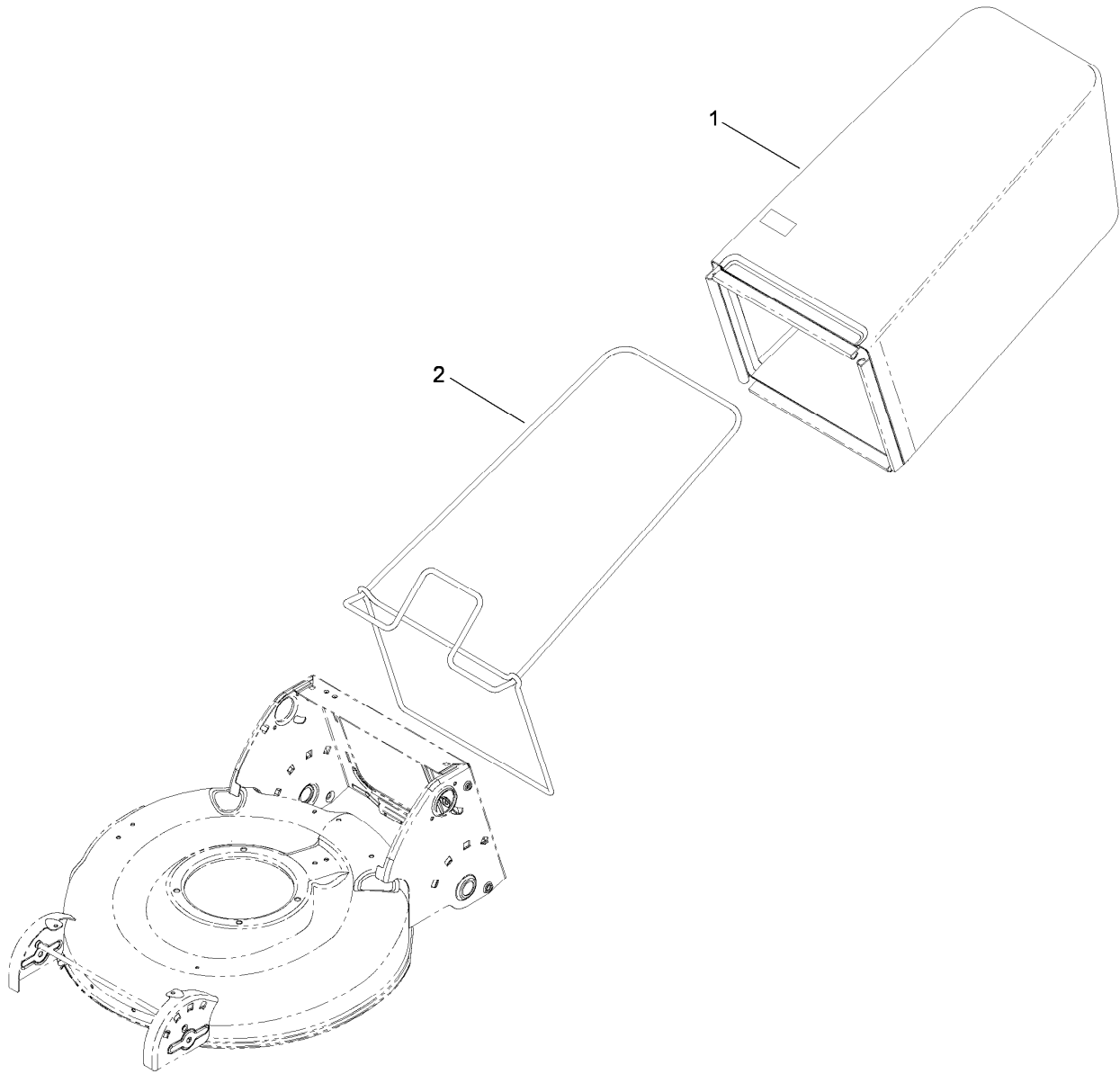

Bag Assembly

<i>Ref.</i>	<i>Part Number</i>	<i>Qty.</i>	<i>Description</i>
1	117-4105	1	Grass Bag ASM
2	112-8750-03	1	Frame-Bag

